

Assignment for SDOF Numerical Solution Procedure (Use Average Acceleration Method)

(Units and axis labels must be clearly shown on all Figures)

Question No. 1

For the SDOF system

$$ma + cv + ku = f(t)$$

Define m , k and c for a system of natural frequency ω_n (of your choice), and a damping ratio of 5%. Shake with 40 cycles of a square wave **base excitation** $\ddot{u}_g(t)$, followed by 10 seconds of free vibration. Plot absolute acceleration and relative displacement. Comment on the result (forced vibration phase, free vibration phase). Estimate damping from your answer using the logarithmic decrement method (is it 5%?..., it should be). Check the natural period of your system as well.

Notes:

- i. Use the suggested normalized values of: $m = 1.0$ kg, $\omega_n = 4\pi$, square wave of 4 cycles per second, input amplitude = 1.0 m/sec/sec, and $\Delta t = 0.0125$ second). Hint: Add trailing zeros to your input excitation vector for the free vibration phase.
- ii. For earthquake base excitation, $f(t)$ is replaced by $-m\ddot{u}_g(t)$ where $\ddot{u}_g(t)$ is the time history of base ground acceleration. **All units must conform to those of this input acceleration (e.g., m/sec/sec).**
- iii. Recall that absolute acceleration is $\ddot{u}_{abs} = (a + \ddot{u}_g)$

Question No. 2

Part No. 2.1

Using a time increment of 0.01 seconds, construct a base excitation consisting of 30 cycles of a sine wave (0.1 m/sec^2 peak amplitude) with a frequency equal to the natural frequency of the tower ω_n , followed by 10 seconds of trailing zeros (to allow for a free vibration phase).

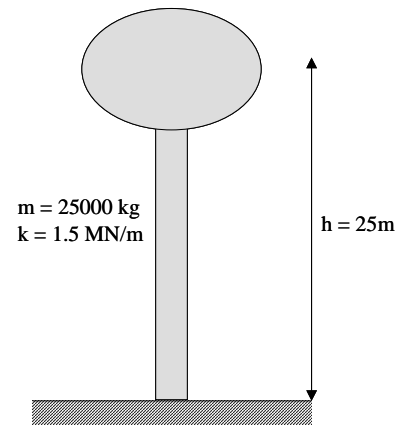

- 2.1.1 Run the SDOF program with zero damping ($\zeta = 0$), and plot the relative displacement time history (including the free vibration phase),
- 2.1.2 Run the SDOF program with 2% damping ($\zeta = 0.02$), and plot the relative displacement time history (including the free vibration phase), and check that maximum steady-state amplitude is $(0.1 / (2 \omega_n^2 \zeta))$ approximately.
- 2.1.3 Comment on the results (forced vibration and free vibration phases).

Part No. 2.2 (Illustration of free-vibration response)

Impose an initial displacement of 25 centimeters and no initial velocity, and run the SDOF simulation for the duration of 15 seconds (cases of $\zeta = 0$ and $\zeta = 0.02$ with no base excitation imparted this time). Comment on the results.

Part No. 2.3 (Illustration of the Beating Phenomenon)

For the case of zero initial displacement and velocity, run 20 seconds of the SDOF program ($\zeta = 0.02$) for:

- a. a sine wave with a frequency equal to $0.90 \omega_n$
- b. a sine wave with a frequency equal to $1.1 \omega_n$

What do you See?

Part No. 2.4 (Earthquake Response)

- 2.4.1 Using a $\zeta = 0.02$, employ the El-Centro 1940 S00E recorded ground motion as your base excitation, and compute (and plot) the SDOF absolute acceleration, and relative displacement.
- 2.4.2 Note that the relative displacement time history clearly displays a dominant period. What is this dominant period, and what does this dominant period reflect.
- 2.4.3 What is the maximum displacement of the tank top relative to the ground?
- 2.4.4 What is the Absolute acceleration of the SDOF. What is the amplification factor of this quantity compared to the peak ground acceleration (PGA).

Part No. 2.5 (Bonus Earthquake Response)

Repeat 2.4 for other base excitation record(s).